

STEAM BOILING PAN

Item:

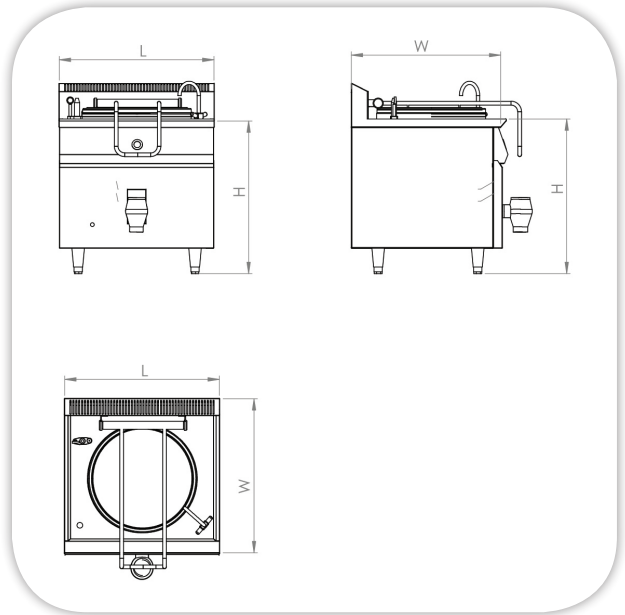

ISO 9001

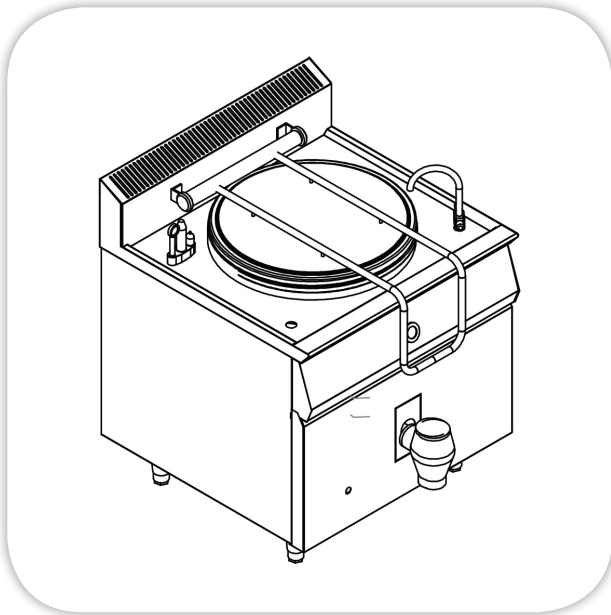

SPECIFICATIONS: (Medium Duty)

Body: Stainless steel (304) construction, pan and jacket, with normal cover with handel, heavy duty hinges, thermal insulation all over the pan.

Control: Thermostatically controlled, water filling, water level, pressure relive, gauges, jacket safety control.

Accessories: Heavy duty, high quality.

Legs: (4) legs, stainless steel, 60 mm diameter, with Adjustable leveling feets.

TECHNICAL DATA:

MODEL	Pan capacity (lt)	Dimensions (mm)			Steam Power (kw/hr)	Net Weight (Kg)
		L	W	H		
MSBP-I-02-12 Steam Boiling Pan	150	900	900	900	23	
MSBP-I-03-12 Steam Boiling Pan	300	1100	1100	900	31	

Masria, In Line with its policy to continually improve its quality, reserves the right to change specs without notice.

+202 44812326/8

masria@masria.com

masriagroup

+201 001609002/10

www.masria.com

masriagr

