

BELL CAPTAIN TROLLEY

Item:

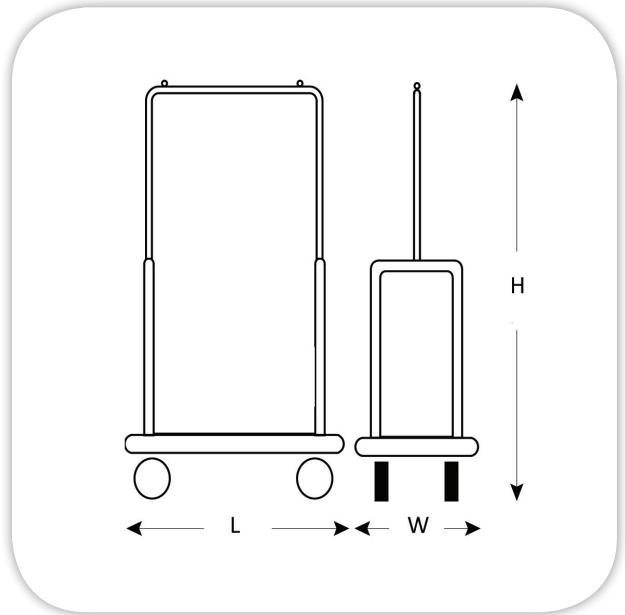

SPECIFICATIONS:

Frame: stainless steel tubes construction, (25mm) diameter, hanging bar tubes, diameter (25mm) with swivel bottom.

Mobile: the trolley On (4) rubber casters diameter (5 inch) two of them with brakes, equipped with protective disc rubber bumpers.

Up-on request: with carpet covered luggage located at bottom (MBC 01-01) with stainless steel carries shelf located at bottom (MBC 02-01).

TECHNICAL DATA:

MODEL	Dimensions (mm)			Net Weight (KG)
	L	W	H	
MBC 03-01 Bell captain trolley with swivel bar at bottom	1300	600	1700	
MBC 01-01 Bell captain trolley with luggage deck at bottom	1150	600	1820	
MBC 02-01 Bell captain trolley with stainless steel shelf at bottom	1150	600	1820	

Masria, In Line with its policy to continually improve its quality, reserves the right to change specs without notice.

+202 44812326/8

masria@masria.com

masriagroup

+201 001609002/10

www.masria.com

masriagr

