

TOP LOADING VEGETABLE WASHER

Item:

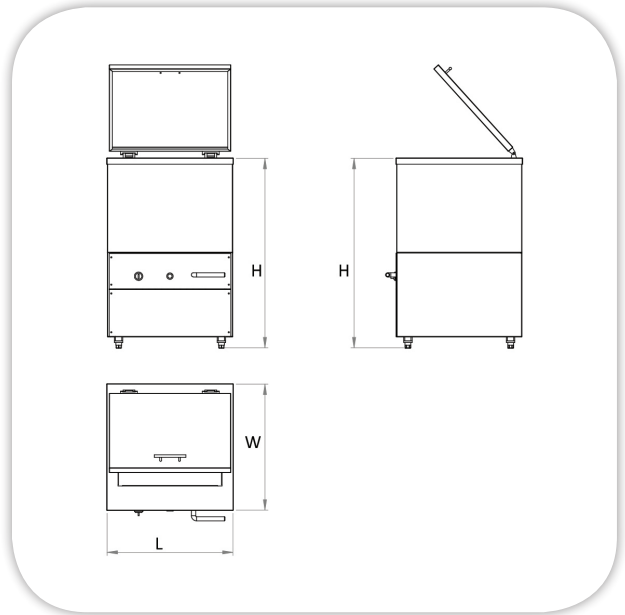

SPECIFICATIONS:

Body: Stainless Steel Construction (304),
Stainless Steel perforated inner Drum, water
inlet overflow pipe & drain & outer drum
2" Electric gate valve.

Washing motor driven pump: 1/2 HP/3 Ph

Electric Source: kW/220V/1ph/50Hz

Washing Time: 2-3 mins

Water inlet: 3/4"

Drainage outlet connect: 1 1/4"

TECHNICAL DATA:

| MODEL | Dimensions (mm) | | | Electric Power | Vegetable Load Capacity (Kg) | | Washing Drum Capacity (ltrs) | Net Weight (KG) |
|--------|-----------------|-----|-----|----------------|------------------------------|-------|------------------------------|-----------------|
| | L | W | H | | Heavy | Leafy | | |
| VW-100 | 600 | 600 | 900 | 0.5 kW | 15 | 4 | 100 | 60 |

Masria, In Line with its policy to continually improve its quality, reserves the right to change specs without notice.

+202 44812326/8

masria@masria.com

masriagroup

+201 001609002/10

www.masria.com

masriagr

