

MOBILE MEAT HANGING RAIL

Item:

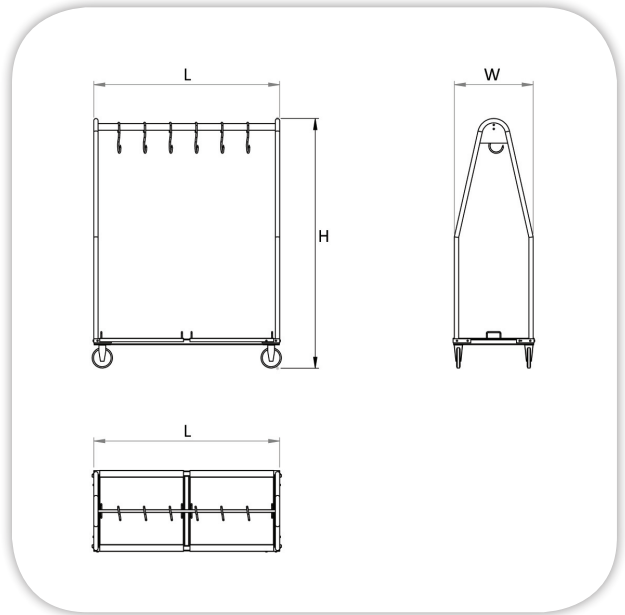
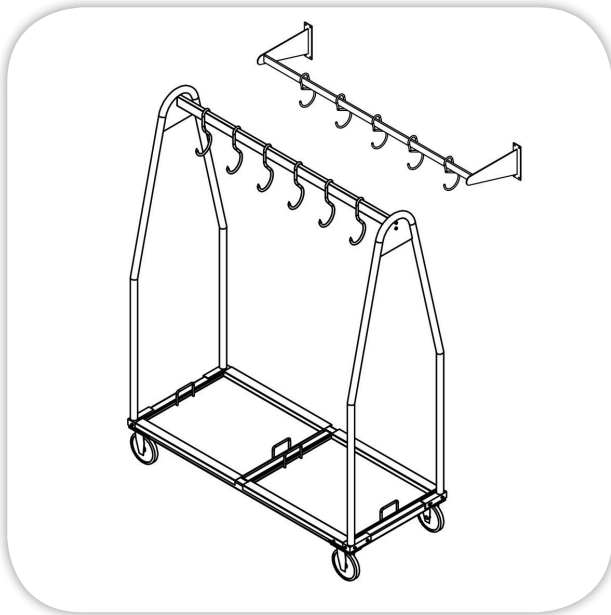

SPECIFICATIONS:

Body: Stainless Steel frame 40 x 40 mm,
 (2) stainless steel posts diameter 320 mm,
 stainless steel carrier bar 10x40 mm.
hooks: Stainless steel 5 hooks 8 mm diameter.

Wheels: (4) rubber casters diameter 5", (2)
 casters equipped with brakes.
 Model (MFP05-03-T) at bottom complete with
 drip tray size of (2) X 2/1 G/N, 20 mm depth.

TECHNICAL DATA:

MODEL	Dimensions (mm)		
	L	W	H
MFP05-03-136	1365	590	1800
MFP05-03-T-136	1365	590	1800

UPON REQUEST: WALL MOUNTED MEAT HANGING RAIL (MFP05-02)

Stainless Steel Construction, length 1500 mm, depth 350 mm, carrier bar 10x40 mm, complete with 5 hooks diameter 8 mm.

Masria, In Line with its policy to continually improve its quality, reserves the right to change specs without notice.

+202 44812326/8

masria@masria.com

masriagroup

+201 001609002/10

www.masria.com

masriagr

