

IRONING BOARD WITH BUILT-IN BOILER

Item:

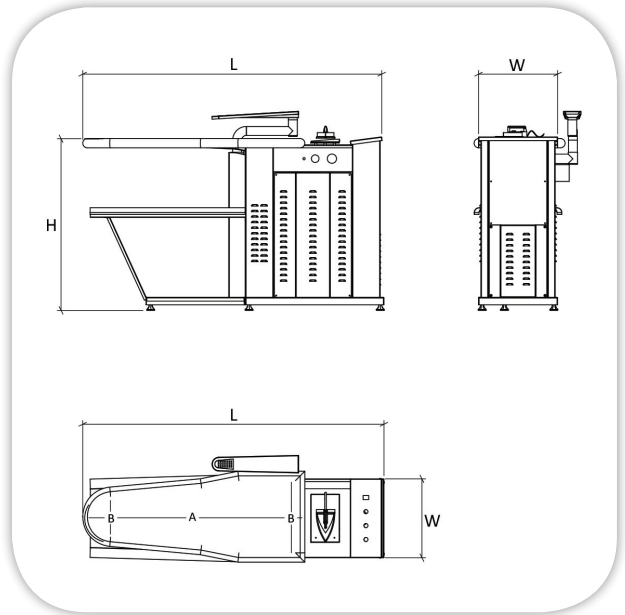

ISO 9001

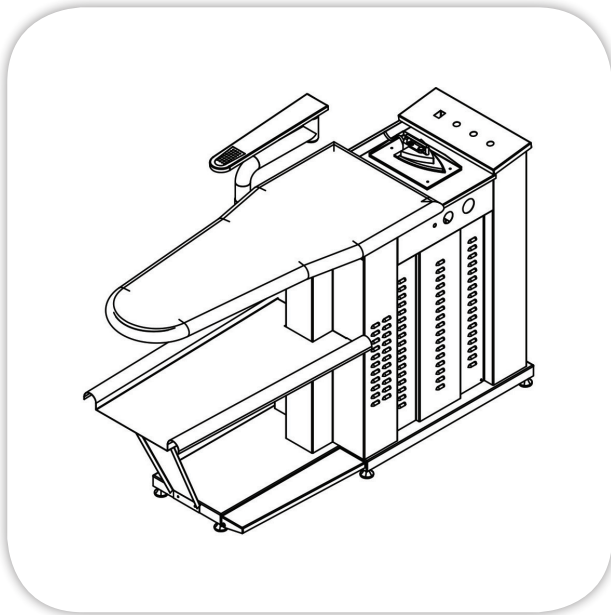

SPECIFICATIONS:

Body: Heavy duty painted steel construction,
Table top coated with thermal insulated form,
Built-in vacuum, Built-in electric boiler
Electric heated vacuum unit
With one electric **or** steam iron 2 kg.
Built-in water feed pump (5 ltrs./hr.)
Electric Source: kW/380V/3ph/50Hz

TECHNICAL DATA:

MODEL	Top Board Dimensions (mm)		Overall Dimensions (mm)			Electric Power
	A	B	L	W	H	
MLIBE-01	1130	430/ 200	1600	430	900	7 kW/380V/3ph/50Hz

Masria, In Line with its policy to continually improve its quality, reserves the right to change specs without notice.

+202 44812326/8

masria@masria.com

masriagroup

+201 001609002/10

www.masria.com

masriagr

