

# IRONING BOARD

Item: .....

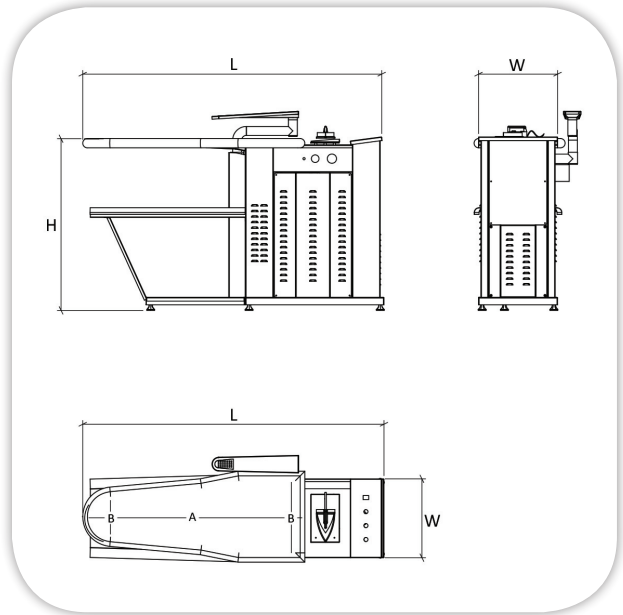

ISO 9001

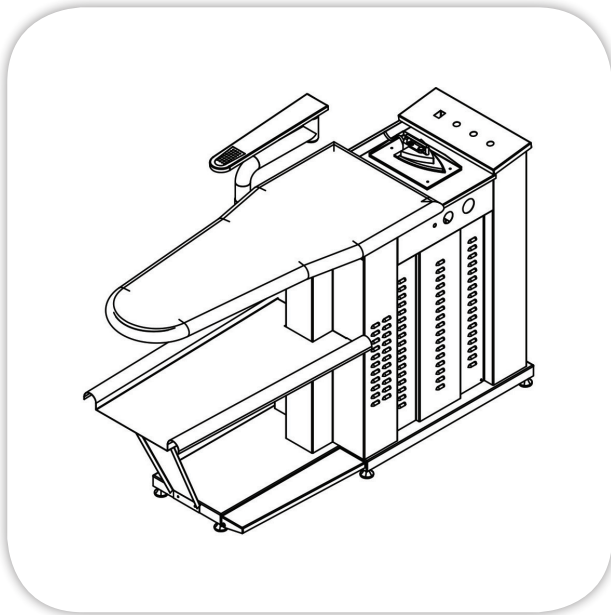

## SPECIFICATIONS:

**Body:** Heavy duty painted steel construction,  
Table top coated with thermal insulated form,  
Electric heated vacuum unit  
With one electric or steam iron 2 kg.  
**Electric Source:** kW/380V/3ph/50Hz

## TECHNICAL DATA:

MODEL	Top Board Dimensions (mm)		Overall Dimensions (mm)			Electric Power
	A	B	L	W	H	
MLIBE-02	1130	430/ 200	1600	430	900	2 kW/380V/3ph/50Hz

Masria, In Line with its policy to continually improve its quality, reserves the right to change specs without notice.

+202 44812326/8

masria@masria.com

masriagroup

+201 001609002/10

www.masria.com

masriagr

