

ELECTRIC SHAWERMA GRILL STATION

Item:

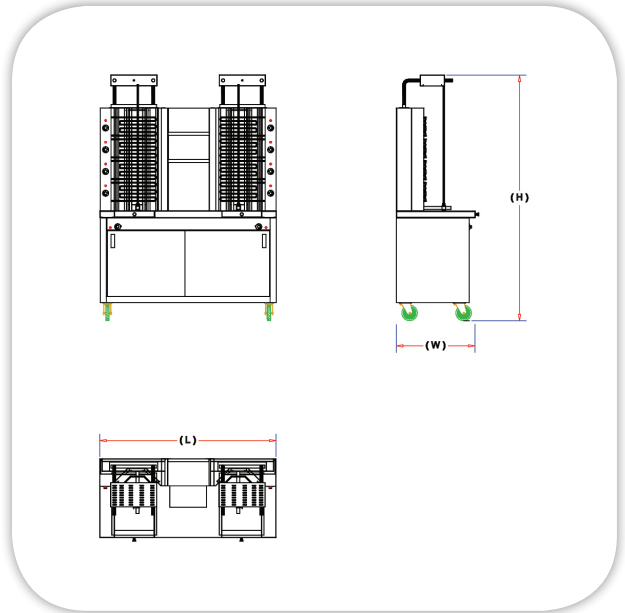
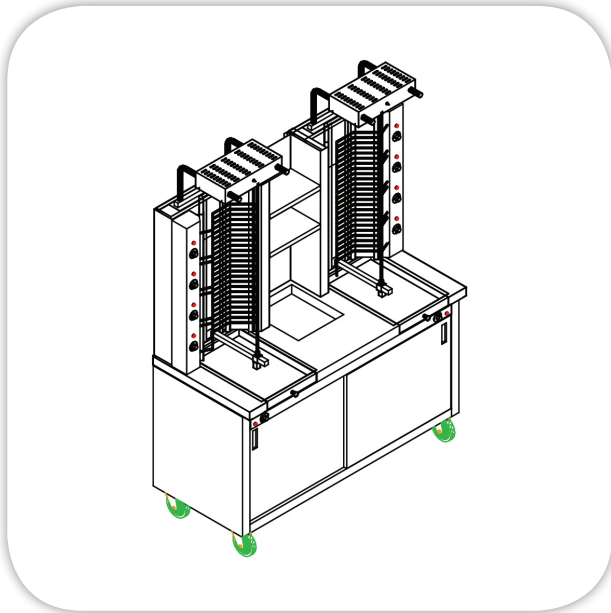

SPECIFICATIONS: (Heavy Duty)

Electric Shawerma Grill station: on Mobile counter.

Counter: Stainless steel (304) construction, (Available Up-on request) Painted steel construction, with middle shelf and two sliding doors, Drop-In at right hand side (3) G/N 1/6 for one rode Model OR at middle for (2) rods model and (2) shelve at back for (2) rods model

Rode: Steel rod, capacity up to 50 K.g meat or chicken perrod, rotated by Electric, moter.

Electric source: 380V/3PH/50Hz.

Tray: Each rode equipped with movable stainless steel (304) preparation tray with Electric heater under-neeth, thermostatically controlled.

Radiation Heater: Each rode equipped by four (4) radiation heaters set, thermostatically controlled

Wheels: (4) rubber casters diameter 5", two of them with brakes

Available Up-on request: G/N

TECHNICAL DATA:

MODEL	Dimensions (mm)			Electric Power (kW)	Net Weight (Kg)
	L	W	H		
MEC01-09+STAND Electric one Rode shawerma Grill station	650	650	1900	9.2	
MEC03-09 Electric two Rods Shawerma Grill station	1500	650	1900	18.4	

Masria, In Line with its policy to continually improve its quality, reserves the right to change specs without notice.

+202 44812326/8

masria@masria.com

masriagroup

+201 001609002/10

www.masria.com

masriagr

