

# ELECTRIC SHAWERMA GRILL

Item: .....

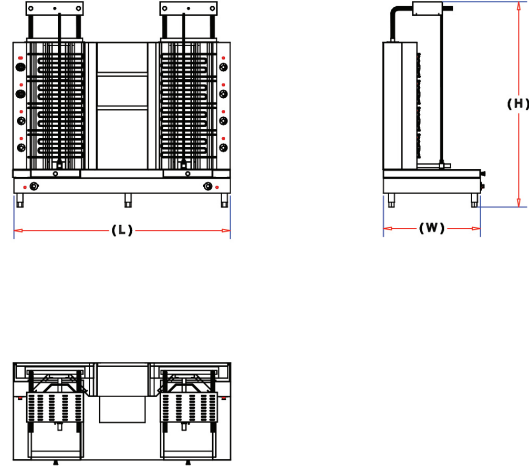

MFC

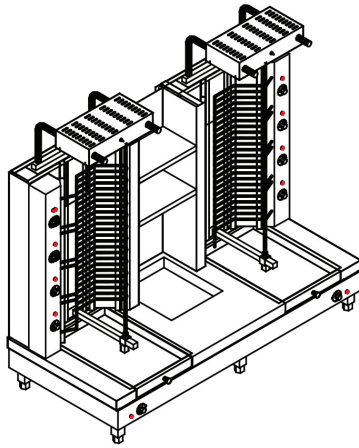

## **SPECIFICATIONS: (COUNTER TYPE)**

**Body:** Stainless steel (304) construction.

**Rode:** Steel rode, capacity up to 50 kg meat or chicken, rotated by Electric motor.

**Preparation Tray:** Stainless steel (304) construction, movable Heated by electric heated.

**Electric Heaters:** Thermostatically control, 4 zones (sets).

**Electric source:** 380V/3Ph/50Hz.

**Electric accessories:** High quality, heavy duty EGO (Germany)

## **TECHNICAL DATA:**

MODEL	Dimensions (mm)			Electric Power (kW)	Net Weight (Kg)
	L	W	H		
MEC01-09 Electric shawerma Grill counter type, one rod	550	650	1150	9.2	
MEC02-09 Electric Shawerma Grill counter type, two rods	1200	650	1150	18.4	

Masria, In Line with its policy to continually improve its quality, reserves the right to change specs without notice.

+202 44812326/8

masria@masria.com

masriagroup

+201 001609002/10

www.masria.com

masriagr

