

ELECTRIC SNACK PASTA COOKER - COUNTER MODEL

Item:

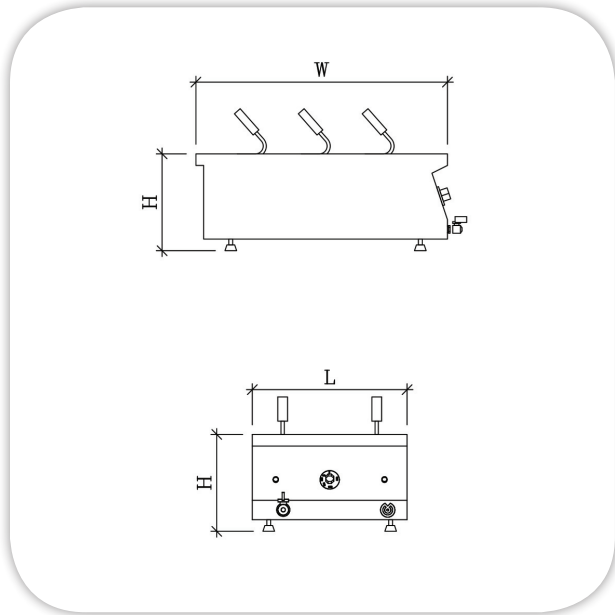
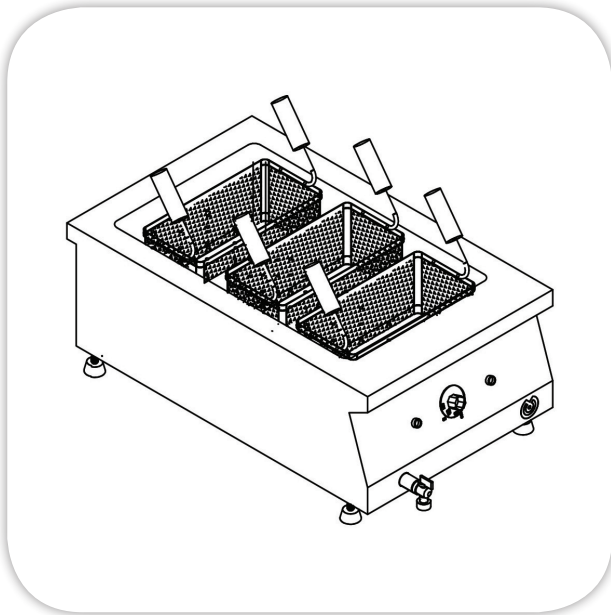

SPECIFICATIONS: (Counter Type)

Body: Stainless steel (304) construction, with Adjustable leveling feet.

Basin: Stainless steel (304) construction, capacity (20 LT), immersing electric heating elements, completed with (3) baskets, one Bottom grid & one drain valve.

Electric source: 380V/3Ph/50Hz.

Baskets: equipped with three (3) baskets per basin.

TECHNICAL DATA:

MODEL	Dimensions (mm)			Electric Power (kW)	Net Weight (Kg)
	L	W	H		
MEC 08-05 Snack Electric Pasta Cooker one well, 3 baskets	400	650	250	6.0	

Masria, In Line with its policy to continually improve its quality, reserves the right to change specs without notice.

+202 44812326/8

masria@masria.com

masriagroup

+201 001609002/10

www.masria.com

masriagr

