

PASS-THROUGH HEATED CABINETS

Item:

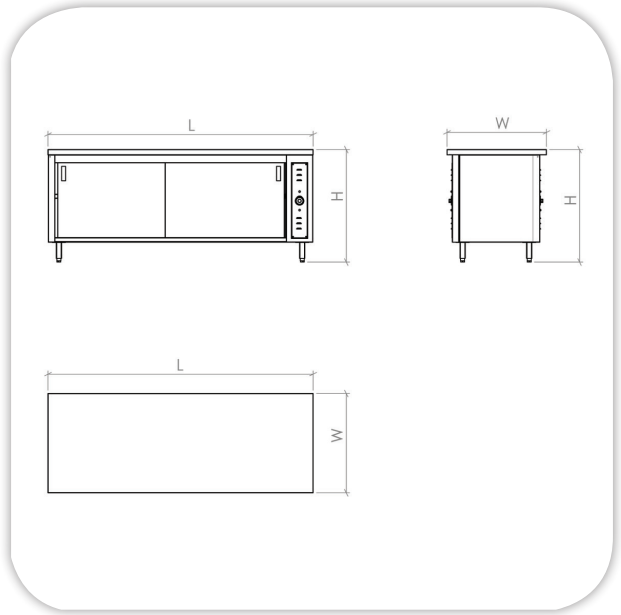
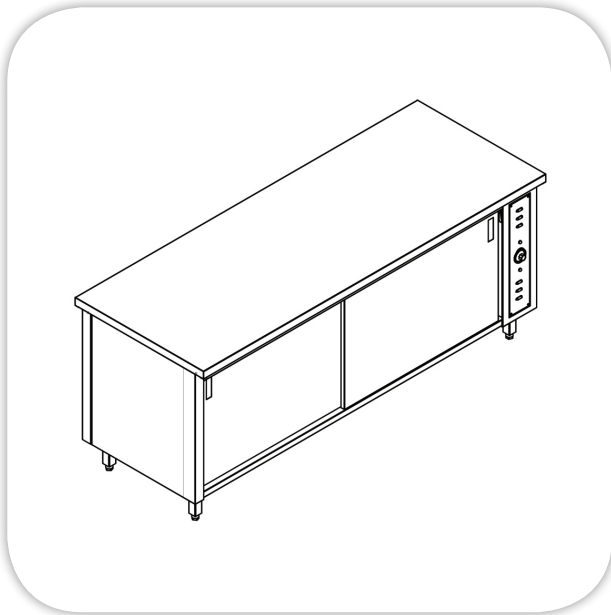

SPECIFICATIONS:

Body: Stainless Steel Construction
Top: Stainless Steel (304) reinforcement and sound deadening material at bottom, top Thickness 1.5 mm
Sliding Doors: two Stainless Steel Sliding Doors, two doors at front, two doors at rear.

Shelves: Stainless Steel, one middle shelf.
Legs: Stainless Steel, (4) Legs, 40 x 40 mm, with adjustable leveling feet.
Thermostatically controlled: (30-80°C), with ON/OFF switch.
Available upon request: Door lock.

TECHNICAL DATA:

MODEL	Dimensions (mm)			Power
	L	W	H	
MFP03-10/200	2000	750	850	2000 watts/220V/1ph/50Hz
MFP03-10/150	1500	750	850	1500 watts/220V/1ph/50Hz
MFP03-10/100	1000	750	850	1000 watts/220V/1ph/50Hz

Masria, In Line with its policy to continually improve its quality, reserves the right to change specs without notice.

+202 44812326/8

masria@masria.com

masriagroup

+201 001609002/10

www.masria.com

masriagr

