

ASSEMBLY BANQUET CENTRAL WORK TABLE

Item:

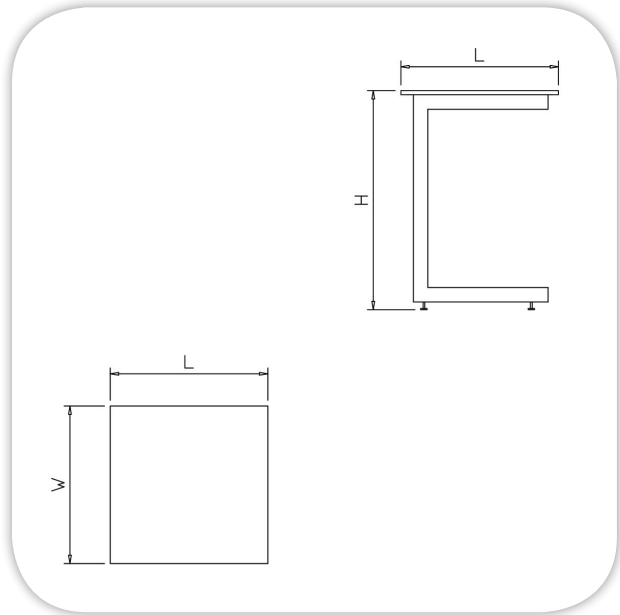
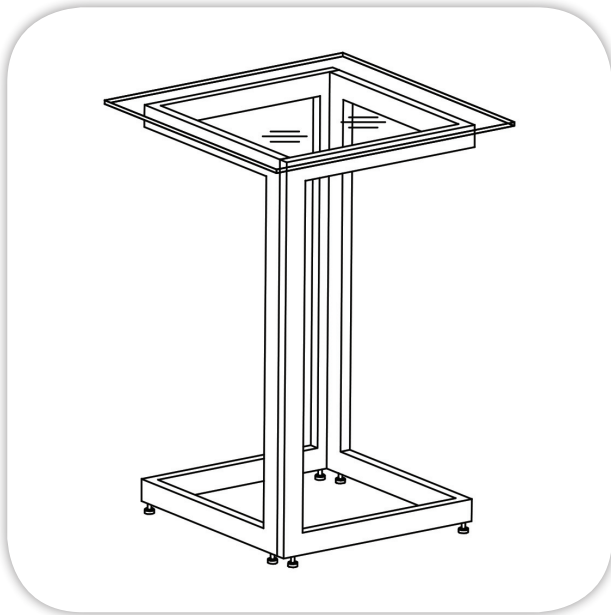

SPECIFICATIONS:

Body: Stainless Steel Construction, Two st.st. right angle 60x60 cm, complete with glass top (10 mm thickness) & vacuum plastic, Washer for assembly

Section: Section 60x30 mm, thickness 2 mm

Legs: Stainless Steel, (4) Legs (diameter 38mm), or (Dimensions 40 x 40mm with added (S) on the model), with adjustable leveling feet.

TECHNICAL DATA:

MODEL	Dimensions (mm)		
	L	W	H
MFP01-01 Semeramis	1830	760	750
	760	760	1100
	760	760	600

Masria, In Line with its policy to continually improve its quality, reserves the right to change specs without notice.

+202 44812326/8

masria@masria.com

masriagroup

+201 001609002/10

www.masria.com

masriagr

