

# SHELVING UNIT

Three (3) adjustable Perforated Shelves

Item: .....  
.....

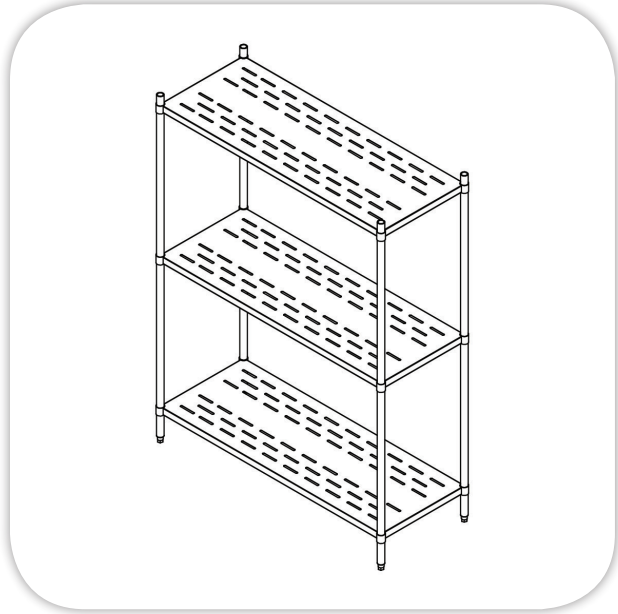
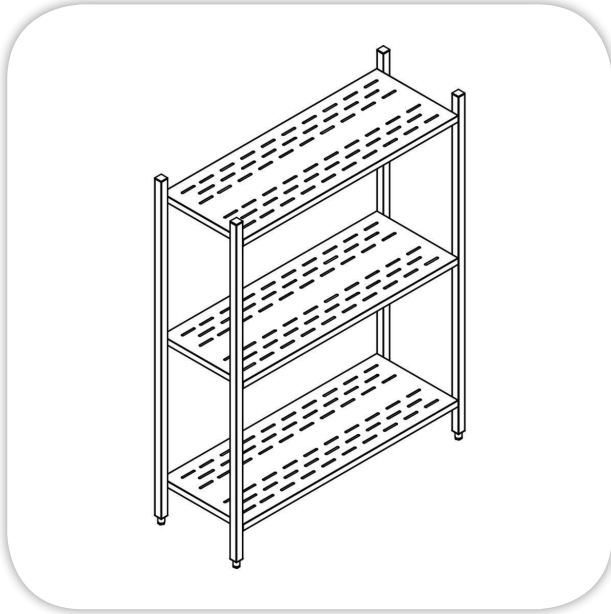

## SPECIFICATIONS:

**Body:** Stainless Steel Construction adjustable Three (3) Stainless Steel (304) **perforated (CNC) Shelves**, thickness 1.25 mm.  
Up Rights, Stainless Steel, with adjustable leveling feet.  
Round Section, Diameter 32 mm                      Models with (R)  
Square Section, 40 X 40 mm                         Models with (S)

## TECHNICAL DATA:

MODEL	Dimensions (mm)		
	L	W	H
MFP04-03-R/90/40	900	400	1800
MFP04-03-R/90/50	900	500	1800
MFP04-03-R/115/40	1150	400	1800
MFP04-03-R/115/50	1150	500	1800
MFP04-03-R/140/40	1400	400	1800
MFP04-03-R/140/50	1400	500	1800

MODEL	Dimensions (mm)		
	L	W	H
MFP04-03-S/90/40	900	400	1800
MFP04-03-S/90/50	900	500	1800
MFP04-03-S/115/40	1150	400	1800
MFP04-03-S/115/50	1150	500	1800
MFP04-03-S/140/40	1400	400	1800
MFP04-03-S/140/50	1400	500	1800

Masria, In Line with its policy to continually improve its quality, reserves the right to change specs without notice.

+202 44812326/8

masria@masria.com

masriagroup

+201 001609002/10

www.masria.com

masriagr

