

SHELVING UNIT

Three (3) adjustable Perforated Shelves

Item:

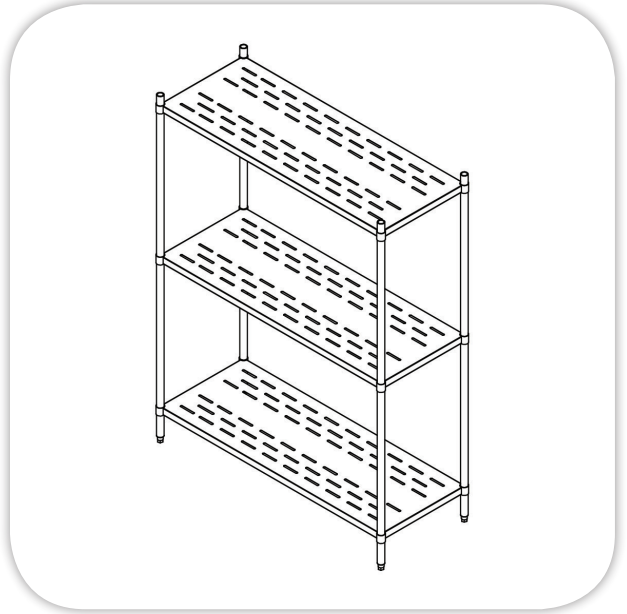
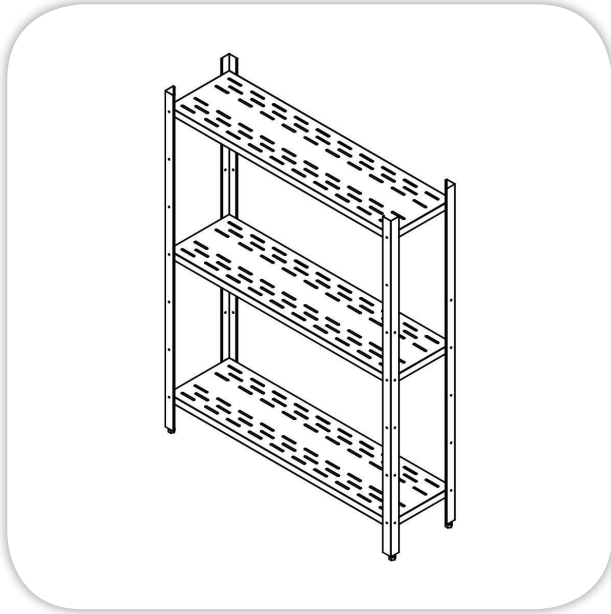

SPECIFICATIONS:

Body: Stainless Steel Construction adjustable Three (3) Stainless Steel (304) **perforated (CNC) Shelves**, thickness 1.5 mm.
 Up Rights, Stainless Steel, with adjustable leveling feet.
 Round Section, Diameter 32 mm Models with (R)
 Angle Section, 50 X 50 mm Models with (L)

TECHNICAL DATA:

MODEL	Dimensions (mm)		
	L	W	H
MFPP04-03-R/90/40	900	400	1800
MFPP04-03-R/90/50	900	500	1800
MFPP04-03-R/115/40	1150	400	1800
MFPP04-03-R/115/50	1150	500	1800
MFPP04-03-R/140/40	1400	400	1800
MFPP04-03-R/140/50	1400	500	1800

MODEL	Dimensions (mm)		
	L	W	H
MFPP04-03-L/90/40	900	400	1800
MFPP04-03-L/90/50	900	500	1800
MFPP04-03-L/115/40	1150	400	1800
MFPP04-03-L/115/50	1150	500	1800
MFPP04-03-L/140/40	1400	400	1800
MFPP04-03-L/140/50	1400	500	1800

Masria, In Line with its policy to continually improve its quality, reserves the right to change specs without notice.

+202 44812326/8

masria@masria.com

masriagroup

+201 001609002/10

www.masria.com

masriagr

